



PerfectFlex®

BROADBAND COAXIAL CABLE



Setting a Higher Standard





Our people are fearless about pursuing new ideas for solutions to our customers' needs. PPC's Perfect Flex™ Broadband Coaxial Cable continues this commitment of unmatched innovation, quality and service.



You know PPC for its:

- **CONNECTORS** we've been manufacturing for the cable industry for over 65 years
- **INNOVATIVE SOLUTIONS** and real value we continue to bring to our customers
- **REPUTATION** as a leader in the broadband, wireless and telecommunications industries
- **200 PLUS PATENTS** making a significant impact on the way your customers receive their service
- **EXTENSIVE TRAINING** in cable preparation, installation and trouble call prevention to more than 100,000 installation technicians around the world



Perfect Flex[®]

BROADBAND COAXIAL CABLE

Perfect Flex™ Broadband Coaxial Cable is backed by the same quality and innovation you've come to know and expect from every PPC product. We've incorporated our extensive knowledge of the cable industry into a cost-competitive coaxial cable product line offering superior performance, unmatched quality assurance practices and environmentally-friendly features.

Perfect Flex™ Coaxial Cable offers:

- Exceptional **ELECTRICAL PERFORMANCE** from 5 MHz to **3 GHz**
- **MICRO-CRACK RESISTANT** with superior results in flexural performance
- Manufactured with 100% **RoHS COMPLIANT MATERIALS**
- **ADVANCED CORROSION INHIBITORS** for quality that is designed to last
- Compliant with **ANSI/SCTE 74, SCTE SPECIFICATION** for Braided 75 Ohm Flexible RF Coaxial Drop Cable
- **100 PERCENT** certified material testing



Quality in an Ever-Changing Industry

We do business in an industry that is changing right before our eyes, and we are committed to keeping pace with the needs of our customers around the world. As a multi-national company, PPC products exceed global standards, as our highly-trained lab technicians hold our products to the most rigid standards anywhere. All PPC manufacturing plants globally are ISO 9001:2008 Registered. Most importantly, the PPC Quality Team knows that products need to work in the real world, not just in the confines of a controlled testing site, so our lab technicians subject our products to the most thorough battery of quality checks and simulations available. From prototype to production, our team takes the extra steps necessary to ensure that our products can stand up to environmental exposure, mechanical, electrical and RF testing, and our own unmatched quality requirements.

We've put that commitment to quality into every inch of Perfect Flex™ Broadband Coaxial Cable.



PerfectFlex®

BROADBAND COAXIAL CABLE



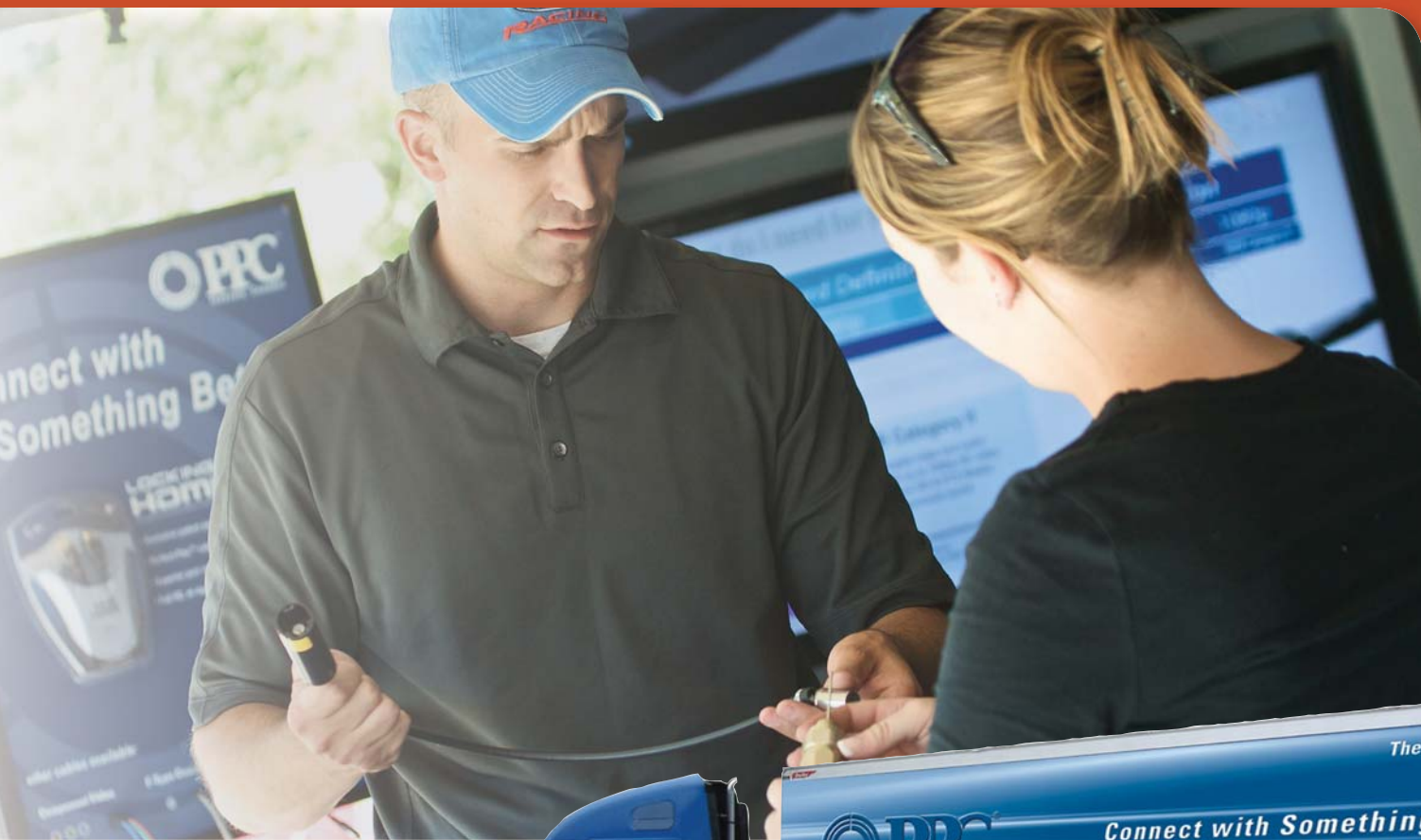

Partnering to Get the Job Done

PPC understands that our innovative products are only as good as the technicians who install them. Even the best drop cable or connector can't always prevent trouble calls from the drop plant due to craft errors or environmental issues. That's why Perfect Flex™ Broadband Coaxial Cable is backed by our partnership with those on the front lines every day. We know cable and we've trained over 100,000 technicians and supervisors in proper cable preparation, exceptional installation practices and trouble call prevention. In turn, we've gathered invaluable insight from these technicians, as we continually fine-tune our training techniques, advance innovation, and ultimately offer our customers a coaxial cable second to none.

We've rolled 65 years of experience in connectors with our know-how of cable into Perfect Flex™ Broadband Coaxial Cable.





With 200 plus patents in connector technology to our credit, we're certain we're making an impact on the industry and our customers. In fact, an August 2008 edition of the *Wall Street Journal* ranked PPC #2 in industry impact among the top 35 most innovative companies worldwide. While we're extremely proud of that accomplishment, it only makes us strive harder to bring new ideas, solutions and real value to the forefront. With Perfect Flex™ Broadband Coaxial Cable, we've done just that.

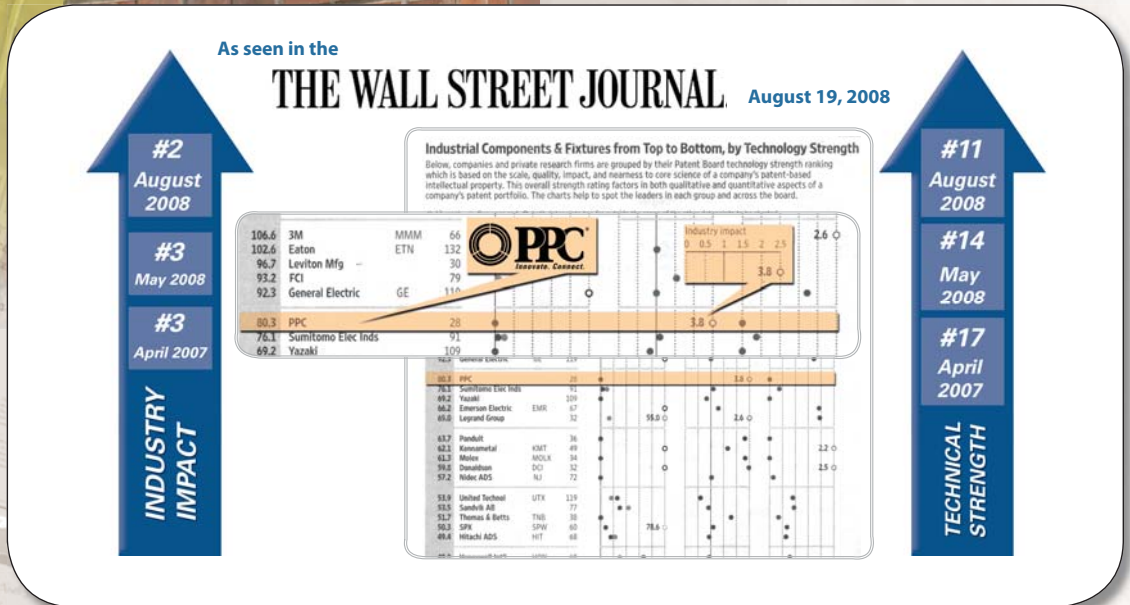



Big Innovation, Small Environmental Footprint

At PPC, we're committed to the global community in which our employees, partners and customers live and work. That's why our cable, boxes, reels and labels meet RoHS requirements. As innovators, we're always on the lookout for ways to minimize our environmental footprint through energy efficiency, waste reduction, recycling and conservation. That means we recycle oil used in the our manufacturing processes, employ air reserve tanks to reduce electrical consumption and use "smog hog" units to maintain low emissions certification. We stand behind our efforts to bring our customers products like Perfect Flex™ Broadband Coaxial Cable that combine "green" manufacturing practices with the quality, service and innovation you've come to expect from PPC.



Perfect Flex®

BROADBAND COAXIAL CABLE

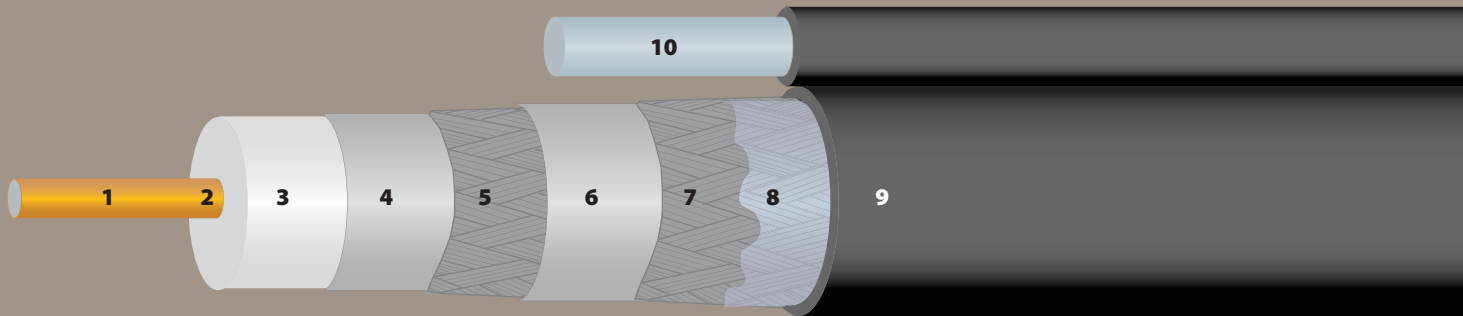

Construction and Materials

- 1 Center Conductor** Copper-clad steel.
- 2 Center Conductor Bond** Proprietary, clean stripping, polymer is utilized to block moisture migration.
- 3 Dielectric** Unique mix of polyethylene providing mechanically stable, closed cell foam with high VP.
- 4 First Outer Conductor** Excellent HF shield isolation before and after flexure is provided by 100% coverage with an aluminum-polymer-aluminum (APA) tape securely bonded to the dielectric core.
- 5 Second Outer Conductor** A 34 AWG aluminum braid is used to improve LF shield isolation and provide additional mechanical strength and stability.
- 6 Third Outer Conductor** An additional aluminum-polymer-aluminum (APA) tape is used in Trishield and Quadshield constructions to further enhance HF shield isolation before and after flexure.
- 7 Fourth Outer Conductor** An additional 34 AWG aluminum braid is used in Quadshield constructions to further improve LF shield isolation in extreme RF noise environments.
- 8 Corrosion Resistant Protectant**
Indoor and Aerial
A non-drip material designed to eliminate moisture migration into the cable construction.
Underground
A flowing compound able to seal small jacket ruptures.
Perfect Guard™
A patent-pending treatment applied to tape and braid that increases corrosion protection.
- 9 Jacket** A UV stable outer jacket of either polyethylene (PE) or flame retardant polyvinyl chloride (PVC) is available to protect the core during installation and for the installed life of the cable.
- 10 Integral Messenger** A galvanized, carbon steel wire support member attached to the cable by a separable web.



Perfect Flex 100% RoHS Compliant Materials

Cable Construction

SHIELDING TYPES

Standard Shield (S) has a fully bonded APA tape with a layer of lead-free shielding braid for outstanding signal protection in EMI environments.

Trishield (T) offers Standard Shield with another layer of APA tape for outstanding signal protection in high EMI environments.

Quadshield (Q) builds on Trishield with another layer of aluminum braided shield for outstanding signal protection in extreme EMI

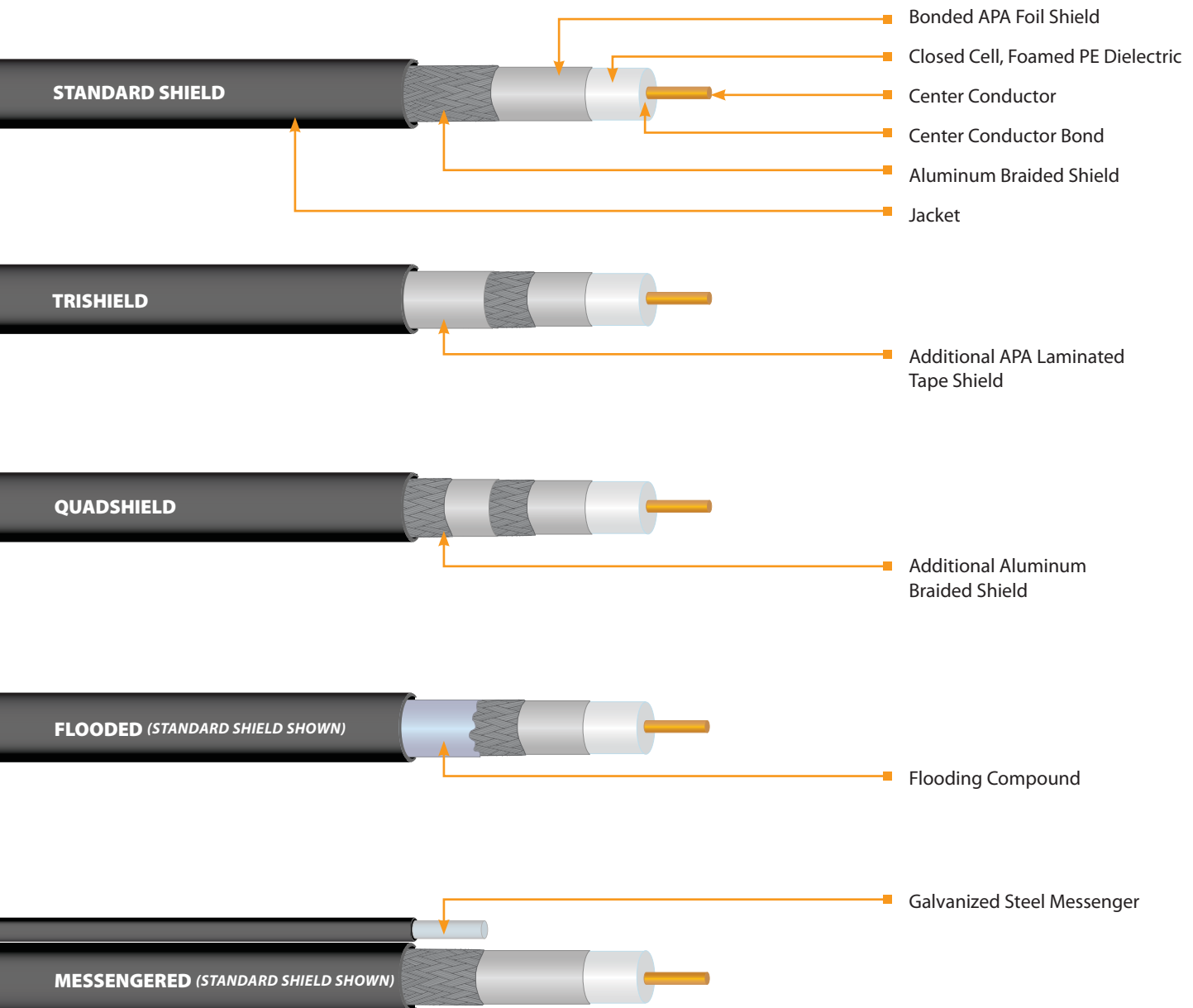

Part Number Identification

P6CS60VYMFWRF

Part Number shown is for illustration purposes only

Indicates PPC Product	P	●
6 series	6	●
11 series	11	●
No entry indicates copper clad steel center conductor (CCS)	()	●
Hard bare copper	C	●
Standard shield	S	●
Trishield	T	●
Quadshield	Q	●
No entry indicates 60/40% braid coverage	()	●
60% Braid coverage	60	●
77% Braid coverage	77	●
90% Braid coverage	90	●
Flame Retardant PVC Jacket	V	●
Polyethylene Jacket	E	●
No entry indicates outdoor, no NEC rating	()	●
NEC CATV Rated (PVC Jacket only)	V	●
NEC CM rated (PVC Jacket only)	Y	●
No entry indicates no messenger	()	●
Cable with 0.051" messenger	M	●
Cable with 0.063" messenger	1	●
Cable with 0.072" messenger	2	●
Cable with 0.083" messenger (11 Series Only)	3	●
Cable with 0.109" messenger (11 Series Only)	4	●
No entry indicates cable is not flooded	()	●
Underground flooded	F	●
Indoor/Outdoor non-drip corrosion resistant coating	C	●
Perfect Guard™ corrosion protection treatment	P	●
No entry indicates black jacket	()	●
Neutral jacket	N	●
Orange jacket	O	●
White jacket	W	●
Reel	R	●
Box Package	B	●
Foot Marked	F	●
Meter Marked	M	●

ORDERING QUESTIONS

Have a question, need 59 series or a non-standard configuration?

Call PPC's customer service to answer your questions and help you find the products and solutions you need, when you need them.

TEL: **315-431-7200**
 ALT: **800-800-6652**
 FAX: **315-431-7201**
 EMAIL: **customerservice@ppc-online.com**

6 Series Drop Cable

Specifications

Compliant with ANSI/SCTE 74, SCTE Specifications for braided 75 Ohm flexible RF coaxial drop cable

Physical Dimensions (Nominal)

Component	Standard Shield		Trishield		Quadshield	
	Inches	mm	Inches	mm	Inches	mm
Center Conductor Diameter	0.040	1.02	0.040	1.02	0.040	1.02
Diameter Over Dielectric	0.180	4.57	0.180	4.57	0.180	4.57
Diameter Over First Shield (Tape)	0.188	4.78	0.188	4.78	0.188	4.78
Diameter Over Jacket	0.273	6.93	0.278	7.06	0.297	7.54
Jacket Wall Thickness	0.030	0.76	0.030	0.76	0.030	0.76

Mechanical Characteristics

Minimum breaking strength of messenger	0.051" (1.3 mm)	170 lbs	77 kg
	0.072" (1.8 mm)	346 lbs	157 kg

Electrical Characteristics

Impedance	75 Ohms ±3
Velocity of Propagation	85% nominal

Attenuation @ 68° F (20° C)

Frequency (MHz)	Max (dB/100 ft)	Max (dB/100 m)
5	0.58	1.90
55	1.55	5.09
211	3.00	9.84
250	3.20	10.50
270	3.30	10.83
300	3.50	11.48
330	3.70	12.14
350	3.80	12.47
400	4.12	13.52
450	4.37	14.34
500	4.63	15.19
550	4.86	15.94
600	5.08	16.67
750	5.65	18.54
870	6.10	20.01
1000	6.54	21.46
1125*	6.93	22.74
1450*	7.86	25.79
1525*	8.10	26.58
1750	8.72	28.61
2000	9.32	30.58
2050	9.45	31.00
2150	9.66	31.69
3000	11.45	37.57

Standard Shield Construction

- 18 AWG copper covered steel center conductor
- Proprietary center conductor bond
- Closed cell foamed PE dielectric
- First shield aluminum-polymer-aluminum laminated tape bonded to dielectric
- Outer shield of braided 34 AWG aluminum wire
- Jacket of PE or flame retardant PVC
- Corrosion resistant protectant (if applicable)

11 Series Drop Cable Specifications

Compliant with ANSI/SCTE 74, SCTE Specifications for braided 75 Ohm flexible RF coaxial drop cable

Physical Dimensions (Nominal)

Component	Standard Shield		Trishield		Quadshield	
	Inches	mm	Inches	mm	Inches	mm
Center Conductor Diameter	0.064	1.63	0.064	1.63	0.064	1.63
Diameter Over Dielectric	0.280	7.11	0.280	7.11	0.280	7.11
Diameter Over First Shield (Tape)	0.288	7.32	0.288	7.32	0.288	7.32
Diameter Over Jacket	0.400	10.16	0.400	10.16	0.407	10.34
Jacket Wall Thickness	0.030	0.76	0.030	0.76	0.030	0.76

Mechanical Characteristics

Minimum breaking strength of messenger	0.072" (1.8 mm)	346 lbs	157 kg
	0.083" (2.1 mm)	427 lbs	194 kg
	0.109" (2.8 mm)	706 lbs	320 kg

Electrical Characteristics

Impedance	75 Ohms ±3
Velocity of Propagation	85% nominal

Attenuation @ 68° F (20° C)

Frequency (MHz)	Max (dB/100 ft)	Max (dB/100m)
5	0.37	1.21
55	0.96	3.15
211	1.85	6.06
250	2.02	6.63
270	2.10	6.90
300	2.21	7.26
330	2.34	7.66
350	2.41	7.89
400	2.58	8.47
450	2.74	9.01
500	2.88	9.44
550	3.04	9.98
600	3.18	10.43
750	3.62	11.87
870	3.94	12.93
1000	4.27	14.02
1450	5.34	17.53
1750	6.01	19.72
2000	6.42	21.08
2050	6.50	21.34
2150	6.67	21.87
3000	7.89	25.88

Standard Shield Construction

- 14 AWG copper covered steel center conductor
- Proprietary center conductor bond
- Closed cell foamed PE dielectric
- First shield aluminum-polymer-aluminum laminated tape bonded to dielectric
- Outer shield of braided 34 AWG aluminum wire
- Jacket of PE or flame retardant PVC
- Corrosion resistant protectant (if applicable)



Perfect Flex®

BROADBAND COAXIAL CABLE

Packaging Specifications

6 Series			
Product Type	Reel Dimensions (F x D x T)	Reels / Pallet	Pallet Dimensions (L x W x H)
Single	12 x 4 x 12	27	37 x 37 x 44
Single Messenger	14.5 x 4 x 11	27	43 x 43 x 41
Single Trishield	12 x 4 x 12	27	37 x 37 x 44
Single Quadshield	12 x 4 x 12	27	37 x 37 x 44
Quad Messenger	14.5 x 4 x 11	27	43 x 43 x 41

all dimensions are in inches

11 Series			
Product Type	Reel Dimensions (F x D x T)	Reels / Pallet	Pallet Dimensions (L x W x H)
Single	18 x 6 x 11	12	37 x 37 x 39
Single Messenger	20 x 6 x 12	12	41 x 41 x 44
Single Trishield	18 x 6 x 11	12	37 x 37 x 39
Single Quadshield	18 x 6 x 11	12	37 x 37 x 39
Quad Messenger	20 x 6 x 12	12	41 x 41 x 44

all dimensions are in inches

Reel in Box Dimensions

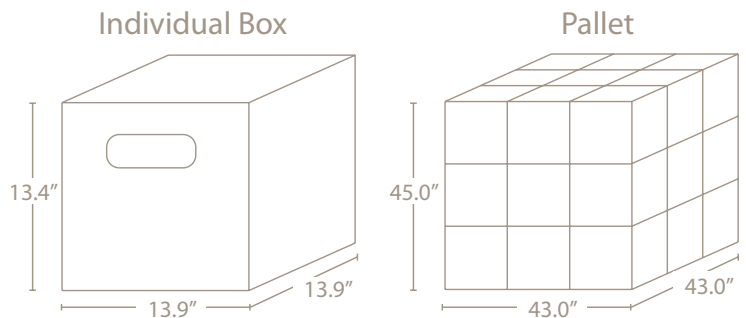

Minimum Purchase Quantity

Product Type	Reels	Boxes
6 Series	9	9
11 Series	4	N/A

Reel Dimensions

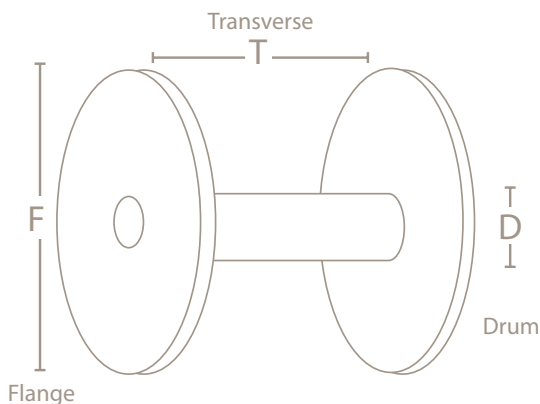

Other Packaging Options:

Perfect Flex™ is available in a variety of options such as jacket colors, meter markings, etc. Additional charges may apply and a higher minimum quantity may be required.

Shipping and Freight Policy

Products are shipped F.O.B. shipping point with freight costs and handling fees paid by PPC for orders totaling \$5,000 or greater to a single ship point. Orders less than \$5,000 (including any backorders) are F.O.B. shipping point, USA. Standard reel lengths are 1,000 feet (+/- 10%). The method of the shipment is at the discretion of the shipper and the quality inspection / acceptance is made at F.O.B shipping point, USA prior to shipment.



ORDERING QUESTIONS

Have a question? Call PPC's customer service to answer your questions and help you find the products and solutions you need, when you need them.

TEL: 315-431-7200

ALT: 800-800-6652

FAX: 315-431-7201

EMAIL: customerservice@ppc-online.com

Part Numbers/Cross Reference (partial listing)

Perfect Flex Part #	Description	Shipping weight lbs/1000' of cable	CommScope Cross Reference	Times Fiber Cross Reference
INDOOR – 6 Series, Standard shield, 60% braid				
P6S60VVRFB	6 Series, Standard shield, 60% braid, NEC CATV rated PVC jacket	30	F660BVV	T660-VBV
P6S60VVWRFB	6 Series, Standard shield, 60% braid, white jacket, NEC CATV rated PVC jacket	30	F660BVV WHT	T660-VCV
P6S60VVNRFB	6 Series, Standard shield, 60% braid, neutral jacket, NEC CATV rated PVC jacket	30	F660BVV NEU	T660-VCV
P6S60VVBF	6 Series, Standard shield, 60% braid, NEC CATV rated PVC jacket, box	30	F660BVV BOX	T660-VCV-7
P6S60VVWBF	6 Series, Standard shield, 60% braid, white jacket, NEC CATV rated PVC jacket, box	30	F660BVV WHT BOX	T660-VCV-7
P6S60VVNBFB	6 Series, Standard shield, 60% braid, neutral jacket, NEC CATV rated PVC jacket, box	30	F660BVV NEU BOX	T660-VCV-7
INDOOR – 6 Series - Trishield, 60% braid				
P6T60VVRFB	6 Series, Trishield, 60% braid, NEC CATV rated PVC jacket	30	F660TSBVV	T6T60-VBV
P6T60VVWRFB	6 Series, Trishield, 60% braid, white jacket, NEC CATV rated PVC jacket	30	F660TSBVV WHT	T6T60-VCV
P6T60VVNRFB	6 Series, Trishield, 60% braid, neutral jacket, NEC CATV rated PVC jacket	30	F660TSBVV NEU	T6T60-VCV
P6T60VVBF	6 Series, Trishield, 60% braid, NEC CATV rated PVC jacket, box	30	F660TSBVV BOX	T6T60-VBV-7
P6T60VVWBF	6 Series, Trishield, 60% braid, white jacket, NEC CATV rated PVC jacket, box	30	F660TSBVV WHT BOX	T6T60-VCV-7
P6T60VVNBFB	6 Series, Trishield, 60% braid, neutral jacket, NEC CATV rated PVC jacket, box	30	F660TSBVV NEU BOX	T6T60-VCV-7
INDOOR – 6 Series - Trishield, 77% braid				
P6T77VVRFB	6 Series, Trishield, 77% braid, NEC CATV rated PVC jacket	33	F677TSBW	T6T77-VBV
P6T77VVWRFB	6 Series, Trishield, 77% braid, white jacket, NEC CATV rated PVC jacket	33	F677TSBVV WHT	T6T77-VCV
P6T77VVNRFB	6 Series, Trishield, 77% braid, neutral jacket, NEC CATV rated PVC jacket	33	F677TSBVV NEU	T6T77-VCV
P6T77VVBF	6 Series, Trishield, 77% braid, NEC CATV rated PVC jacket, box	33	F677TSBVV BOX	T6T77-VBV-7
P6T77VVWBF	6 Series, Trishield, 77% braid, white jacket, NEC CATV rated PVC jacket, box	33	F677TSBVV WHT BOX	T6T77-VCV-7
P6T77VVNBFB	6 Series, Trishield, 77% braid, neutral jacket, NEC CATV rated PVC jacket, box	33	F677TSBVV NEU BOX	T6T77-VCV-7
INDOOR – 6 Series – Quadshield, 60/40% braid				
P6QVVRFB	6 Series, Quadshield, 60/40% braid, NEC CATV rated PVC jacket	38	F65SBVV	T6Q-VBV
P6QVVWRFB	6 Series, Quadshield, 60/40% braid, white jacket, NEC CATV rated PVC jacket	38	F65SBVV WHT	T6Q-VCV
P6QVVNRFB	6 Series, Quadshield, 60/40% braid, neutral jacket, NEC CATV rated PVC jacket	38	F65SBVV NEU	T6Q-VCV
P6QVVBF	6 Series, Quadshield, 60/40% braid, NEC CATV rated PVC jacket, box	38	F65SBVV BOX	T6Q-VBV-7
P6QVVWBF	6 Series, Quadshield, 60/40% braid, white jacket, NEC CATV rated PVC jacket, box	38	F65SBVV WHT BOX	T6Q-VCV-7
P6QVVNBFB	6 Series, Quadshield, 60/40% braid, neutral jacket, NEC CATV rated PVC jacket, box	38	F65SBVV NEU BOX	T6Q-VCV-7
INDOOR – 11 Series –Trishield, 60% braid				
P11T60VVRFB	11 Series, Trishield, 60% braid, NEC CATV rated PVC jacket	73	F1160TSBVV	T11T60-VBV
P11T60VVWRFB	11 Series, Trishield, 60% braid, white jacket, NEC CATV rated PVC jacket	73	F1160TSBVV WHT	T11T60-VCV
P11T60VVNRFB	11 Series, Trishield, 60% braid, neutral jacket, NEC CATV rated PVC jacket	73	F1160TSBVV NEU	T11T60-VCV
OUTDOOR – 6 & 11 Series – Aerial				
P6S60VMRFB	6 Series, 60% braid, PVC jacket with 0.051" integral messenger	45	F660BVM	T660-VB-051M
P6T60VMRFB	6 Series, Trishield, 60% braid, PVC jacket with 0.051" integral messenger	45	F660TSBVM	T6T60-VB-051M
P6T77VMRFB	6 Series, Trishield, 77% braid, PVC jacket with 0.051" integral messenger	47	F677TSBVM	T6T77-VB-051M
P6QVMRFB	6 Series, Quadshield, 60/40% braid, PVC jacket with 0.051" integral messenger	50	F65SBVM	T6Q-VB-051M
P11T60V2RFB	11 Series, Trishield, 60% braid, PVC jacket with 0.072" integral messenger	93	F1160TSBVM	T11T60-VB-072M
OUTDOOR – 6 & 11 Series – Underground				
P6S60EFRFB	6 Series, 60% braid, PE jacket with flooding compound	31	F660BEF	T660-FEB
P6T60EFRFB	6 Series, Trishield, 60% braid, PE jacket with flooding compound	32	F660TSBEF	T6T60-FEB
P6T77EFRFB	6 Series, Trishield, 77% braid, PE jacket with flooding compound	33	F677TSBEF	T6T77-FEB
P6QEFRFB	6 Series, Quadshield, 60/40% braid, PE jacket with flooding compound	37	F65SBEF	T6Q-FEB
P11T60EFRFB	11 Series, Trishield, 60% braid, PE jacket with flooding compound	64	F11TSBEF	T11T60-FEB

Customer Service That's Second to None



From innovative product solutions to world-class lead times,

PPC backs every product with customer service and sales expertise that is unmatched in our industry. Our goal is to provide our customers with the fastest, most efficient and cost-effective solutions to make your business thrive.

We guarantee shipment of Perfect Flex™ Broadband Coaxial Cable, along with 65 other best-selling products, within 24 hours of your order, and PPC offers Vendor Managed Inventory (VMI) to ensure consistent product availability. In addition, PPC has a 24/7 disaster line and an Emergency Management Team (EMT) because we want our products in your hands when you need them the most.

PPC's Customer Service Department operates from 8:00 a.m. to 6:30 p.m. (EST), Monday through Friday, to answer your questions and help you find the products and solutions you need, when you need them.

PPC WORLD HEADQUARTERS

6176 East Molloy Road
East Syracuse, New York 13057-0278

TEL: **315-431-7200**
ALT: **800-800-6652**
FAX: **315-431-7201**
EMAIL: **customerservice@ppc-online.com**

PPC EUROPEAN HEADQUARTERS

Vaerkstedsvej 14
DK-4720, Praesto, Denmark

TEL: **+45-55-99-17-22**
FAX: **+45-55-99-27-22**
EMAIL: **ppceurope@ppc-online.com**

Standard Product Terms & Conditions – PPC Broadband Coaxial Cable Products

- Terms stated herein are the complete, final, and exclusive agreement in regards to sale with respect to PPC Broadband Coaxial Cable Products. Acceptance of this Agreement must be made on its exact terms.
- Payment terms are net 30 days, after transmission or rendering of PPC's invoice.
- Delivery terms are EXW PPC's manufacturing facility. Risk of loss shall pass to Buyer upon delivery to carrier at the PPC plant. Dates of delivery are determined from the date of PPC acceptance of any order or orders by Buyer or its authorized agent or representative and are estimates of approximate dates of delivery, not a guaranty of a particular delivery date. PPC shall not be liable for failure or delay in shipping Products hereunder if such failure or delay is due to any cause beyond PPC's control including, but not limited to, an act of God, fire, flood, sabotage, war, labor difficulties, accidents, disease, pestilence, riot, insurrection, act of any governmental authority, priorities granted at the request or for the benefit directly or indirectly of any government or agency thereof, shortage of raw materials or components, inability to meet current sales requirements, non-performance by vendors or subcontractors.
- No agent, employee or representative of PPC has any authority to bind PPC to any affirmation, representation or warranty concerning the Products sold under this Agreement and unless an affirmation, representation or warranty made by an employee or representative of PPC is specifically included within this Agreement, it is not a part of the basis of bargain and shall not be enforceable against PPC. This section excepts any authorized extended warranty program PPC may offer from time to time at its sole discretion.
- If the Product is to be prepared or manufactured according to the Buyer's specifications, the Buyer shall indemnify and hold harmless PPC and its officers, directors and employees against any liability for Product performance, or for patent, trademark, copyright, or trade secret infringement due to such preparations, manufacture, sales or use of such Product.
- Any tax, duty or fee imposed by a Federal, State or other Governmental authority on the sale of the Products referred to in this Agreement, inclusive of import, export and environmental or recycling fees shall be paid by the Buyer, in addition to the purchase price.
- PPC warrants, for a period of **one (1) year** after delivery to the original Buyer, Product shall be free of defects in material and workmanship. The obligation of PPC under this warranty is strictly limited to the repair, correction, or replacement of Product at its factory, or, at PPC's option, at the Buyer's facility. PPC reserves the right to make substitutions or design changes in repaired or replaced Product without notice and without any obligation to make the same or similar changes to units previously manufactured. Liability in warranty hereunder is subject to and requires the fulfillment of the following conditions:
 - Limited Warranty: PPC's liability for any Product defects hereunder shall be limited to the value of the purchased Products only. PPC shall have no liability for removing Product after installation, for the installation of repaired or replaced Product, or for the remediation of the Product installation. This warranty does not apply to Product which has been disassembled or modified or subjected to condition(s) exceeding the specifications or set ratings identified by PPC Engineering. This warranty does not apply to any Products which have been subjected to unauthorized repair or alteration or which have been subjected to misuse or abuse. Upon PPC's verification of the sample defect, PPC will, at its option, repair or replace the defective unit(s) and return, freight collect, to the Buyer. This warranty is the extent of the obligation or liability assumed by PPC with respect to the Products. No other warranty or guarantee is expressed or implied. PPC SPECIFICALLY DISCLAIMS ANY LIABILITY FOR INCIDENTAL, CONSEQUENTIAL OR OTHER DAMAGES RESULTING FROM THE USE OF PRODUCTS OTHER THAN THE LIABILITY STATED ABOVE. THIS WARRANTY IS IN LIEU OF ALL OTHER WARRANTIES, EXPRESS OR IMPLIED, INCLUDING BUT NOT LIMITED TO THE IMPLIED WARRANTIES OF MERCHANTABILITY OR FITNESS FOR USE OR PURPOSE. **Buyer is solely responsible to insure that Products are properly installed and used in accordance with any and all applicable laws, codes and regulations.**
 - Return Authorization: Within one (1) year after delivery to the original Buyer, any PPC Product hereunder suspected to be defective may be returned to PPC, along with proof of purchase documentation, only pursuant to the PPC return material authorization (RMA) process. Products will not be accepted for return without advance written approval providing a PPC Customer Service Department RMA number. All returns must be freight prepaid. Otherwise returned Product, only as authorized by the PPC Customer Service Department, at its discretion, shall be subject to restocking fees.
- Terms of payment shall be subject to approval of PPC Credit (Accounting) Department and in case of doubt arising at any time as to Buyer's financial responsibility, production may be stopped and shipments suspended until satisfactory assurances are received. PPC shall be under no obligation to make any shipment when Buyer is in default hereunder or under any other sales agreement between PPC and Buyer.
- Security for payment. To secure the payment of any unpaid balances, the Buyer does hereby transfer, set over, grant and convey to PPC a security interest in the Products and each of the parts thereof delivered pursuant to this Agreement together with all replacement parts, additions, repairs and accessories incorporated thereto and/or hereafter affixed thereto; to have and to hold the said security interests in said Products and each of the parts thereof forever, provided however that if Buyer shall make or cause to be made according to the terms hereof, payment in full, in cash for the Products and shall keep and perform the covenants and agreements herein contained, then this transfer shall be void; otherwise it shall remain in full force and effect.
- Attorney in Fact. Buyer hereby irrevocably appoints PPC or its assignee its attorney in fact to file any financing statements or other documents and agreements to do what PPC or its assignee may deem necessary to continue to perfect the security interests created by this Agreement and to protect the Products and each of the parts thereof.
- This Agreement shall be governed by the laws of the State of New York. PPC has made every effort to assure the accuracy of the information contained in this document. PPC is not, however, responsible for any errors and/or omissions.
- For any cancelled order, Buyer will be liable for all charges incurred by PPC for costs associated with the manufacturing of the Products up to the date of cancellation. This may be up to 100% of the value of the Products based on the disposition of the materials at the time the order is cancelled. Orders are subject to a 100% fee due to the customization of the design for each part.
- In keeping with ongoing Product improvement, PPC reserves the right to make Product changes at any time without notice. PPC will be pleased to assist its customers in the proper selection from its Product lines. However, final responsibility for assuring that the Product selected is suitable for the Buyer's application rests with the Buyer.
- Prices and/or terms are subject to change by PPC only without notice. From time to time, at its discretion, PPC may authorize and offer an extended warranty for Products to be purchased by Buyer which may modify, amend or cancel certain terms hereunder.



PPC WORLD HEADQUARTERS

6176 East Molloy Road
East Syracuse, New York 13057-0278

TEL: **315-431-7200**
ALT: **800-800-6652**
FAX: **315-431-7201**
EMAIL: **customerservice@ppc-online.com**

PPC EUROPEAN HEADQUARTERS

Vaerkstedsvej 14
DK-4720, Praesto, Denmark

TEL: **+45-55-99-17-22**
FAX: **+45-55-99-27-22**
EMAIL: **ppceurope@ppc-online.com**

PPC Broadband Coaxial Cable – Extended 5-Year Material and Workmanship Warranty

PPC (John Mezzalingua Associates, Inc.) provides this Warranty for its PPC Broadband Coaxial Cable Products in lieu of all other warranties express or implied, including those contained in its standard terms or conditions of sale. PPC warrants that, for a period of **five (5) years** following the date of delivery to the original Customer, its PPC Broadband Coaxial Cable products ("Products") shall be free from defects in material and workmanship. The foregoing Warranty is subject to the terms, limitations and conditions set forth below.

PPC's sole liability under this Warranty will be, at its discretion, to repair or replace any Product that is determined by it to be out of compliance with the agreed upon PPC Engineering Product Specifications such as those that may be incorporated from PPC Product literature or the PPC catalog where non-compliance is due to defects in material and workmanship alone. PPC shall not be liable for removing cable after installation, for the installation of repaired or replaced cable, or for remediation of the installation. **It is the sole responsibility of the customer to insure that Products are properly installed, and used, both in accordance with any and all applicable laws, codes and regulations.**

This Warranty does not cover and shall be void for defects or damages resulting from misuse or abuse, neglect, alterations, improper installation, mishandling, transportation or shipment damage, improper operation or maintenance, improper connections with peripherals, or other causes not arising out of defects in materials or workmanship. Proof of purchase in the form of a bill of sale, invoice or sales receipt must be presented to obtain this Warranty. PPC must receive written notice of such Warranty claim within the **five (5) year** period above or such Warranty shall conclusively be deemed to be waived. This Warranty shall be void if the original buyer/transferee transfers ownership of the Product for use, unless PPC is notified in writing of the name and address, within fifteen (15) days after date on which the transfer is made. This restriction on ownership transfer is not applicable if the original buyer is an authorized distributor of PPC, but shall thereafter apply to the subsequent owner. PPC does not assume or authorize any third party agent, or employee other than its President to change the terms of this Warranty or assume for it any other liability or obligation in connection with the sale or use of the Product. There are no oral agreements or warranties collateral to or affecting any sale of the Product.

EXCEPT AS STATED IN THIS EXPRESS WARRANTY, PPC DISCLAIMS ANY AND ALL WARRANTIES ON THE PRODUCT, WHETHER EXPRESS OR IMPLIED, INCLUDING, BUT NOT LIMITED TO, ANY WARRANTY OF MERCHANTABILITY, FITNESS FOR A PARTICULAR PURPOSE OR ARISING FROM COURSE OF DEALING, USAGE OF TRADE, STATUTE OR LAW. IN NO EVENT SHALL PPC BE LIABLE FOR ANY SPECIAL, INCIDENTAL, PUNITIVE, EXEMPLARY OR CONSEQUENTIAL DAMAGES (INCLUDING WITHOUT LIMITATION, LOSS OF USE, LOSS OF PROFIT AND CLAIMS OF THIRD PARTIES), HOWEVER CAUSED, WHETHER BASED IN CONTRACT, TORT, WARRANTY OR OTHERWISE. TO THE EXTENT THAT ANY IMPLIED WARRANTIES MAY NOT BE DISCLAIMED, THEY ARE EXPRESSLY LIMITED TO THE DURATION OF THE WARRANTY PERIOD AS STATED ABOVE. PPC'S LIABILITY FOR ALL CLAIMS, WHETHER BASED ON BREACH OF CONTRACT, NEGLIGENCE, PRODUCT LIABILITY, WARRANTY OR OTHERWISE RELATING TO THE PRODUCT SHALL NOT EXCEED THE PRICE PAID BY CUSTOMER FOR THE PRODUCT IN QUESTION.



REV 1109